

Test Data Sheet

PM11-VIS

S/N:

Resonant electro-optic phase modulator

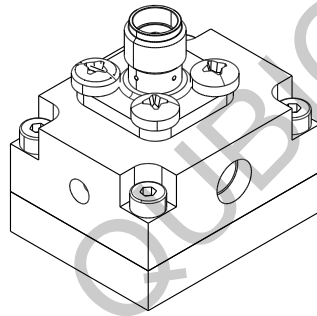

RF properties	Value	Unit
Resonance frequency: f_0 ¹⁾	17.44 - 17.59	GHz
Preset frequency: f_{set} ¹⁾	17.5	GHz
Bandwidth: $\Delta\nu$	165	MHz
Quality factor Q	106	
Required RF power for 1 rad @ 369 nm	28.6	dBm
max. RF power: RF_{max} ²⁾	5	W

Optical properties		
EO crystal	MLN	
Aperture	∅ 1.0	mm
Wavefront distortion (@ 633 nm)	$\lambda/4$	
recommended max. optical intensity (@ 369nm)	< 0.1	W/mm ²
AR coating ($R_{avg} < 1\%$)	360 - 650	nm

¹⁾ at 23.0 °C ²⁾ no damage with $RF_{in} < 5W$, but use of a proper heatsink is strongly recommended at high powers

Measured phase modulation

Fig. 1: Oscilloscope trace

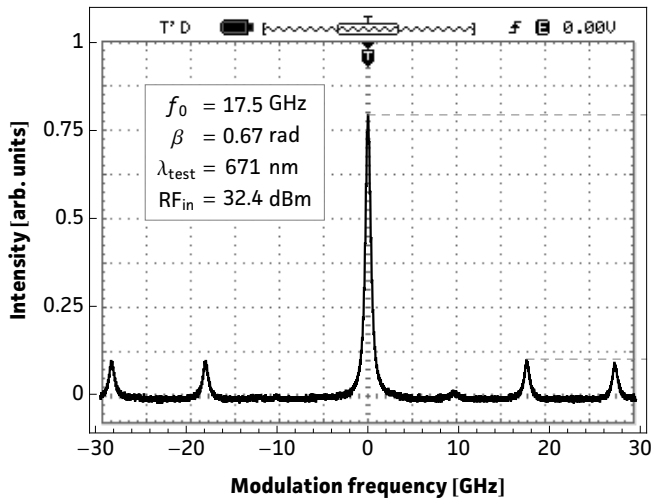

Fig. 2: Carrier/sideband ratio

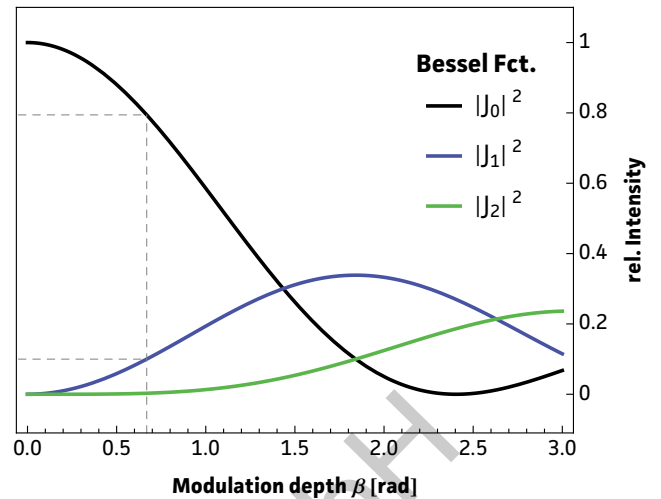

Table 1: Expected modulation

$\beta = 1 \text{ rad}$	unit	λ_1	λ_2	λ_3
λ	nm	369	671	780
P	dBm	28.6	35.9	37.4
P	W	0.73	3.88	5.48
U	V _p	8.5	19.7	23.4
U_π	V _p	26.8	61.9	73.6
β/U	rad/V	0.12	0.05	0.04

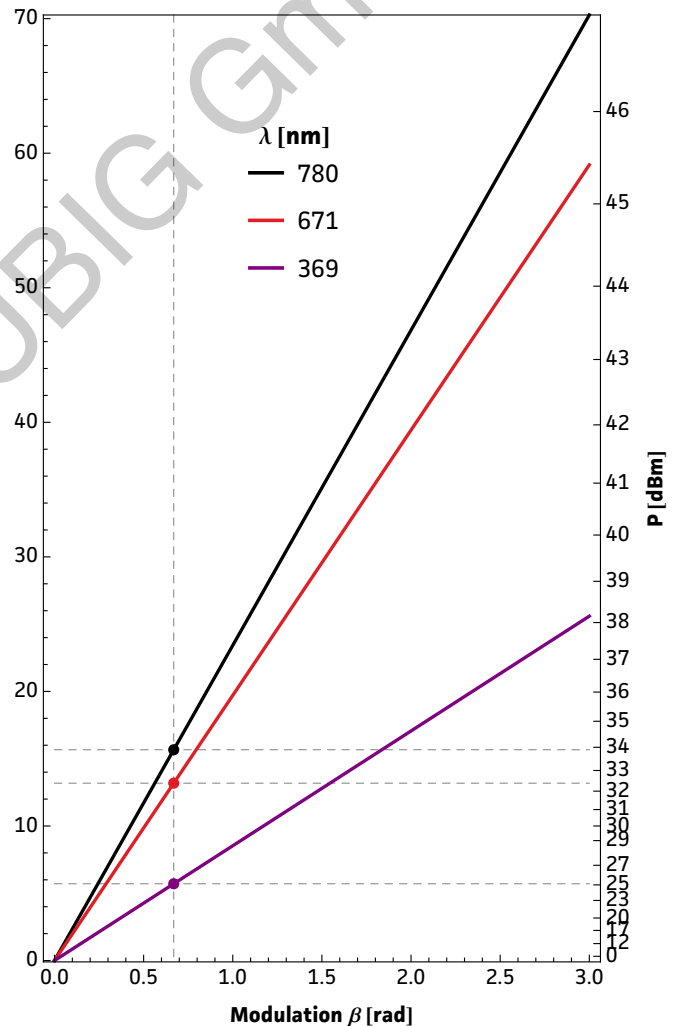

Fig. 1: Recorded oscilloscope trace retrieved from a test setup as illustrated below.

Fig. 2: Squared absolute values of first-kind Bessel functions vs. modulation depth. Vertical lines reveal the ratio between the carrier $|J_0|^2$ and the i^{th} sideband $|J_i|^2$ at a specific β .

Fig. 3: Dependency between RF amplitude and modulation depth for different wavelengths. Points on the curve allow to retrieve either the required RF amplitude for a specific/desired β or the max. achievable modulation depth for a given/available RF power.

Table 1: Expected RF-amplitude/-power values and conversion factors for the required wavelength at the reference modulation depth of 1 rad. **Note:** Experimentally recorded modulation depth displayed in Fig. 1 might vary from the respective values ($\beta=1\text{rad}$) provided in the table.

Fig. 3: RF-signal amplitude vs. modulation depth

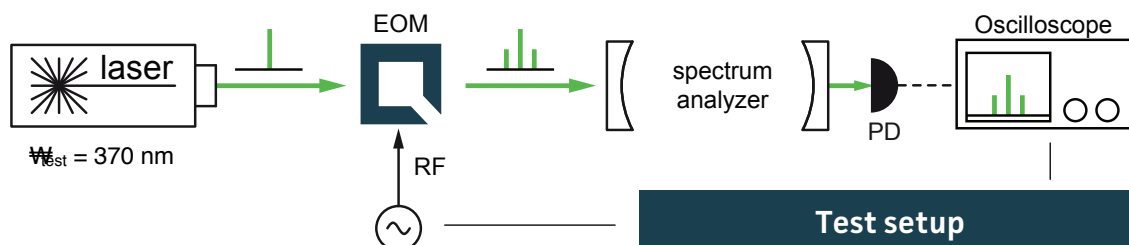

Resonance characteristics

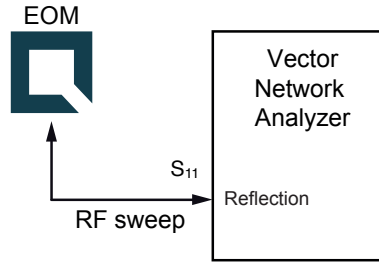

$T_{EOM} = 23.0\text{ }^{\circ}\text{C}$

Trc1 — S11 dB Mag 2 dB/ Ref -8 dB Cal int Trc2 — S11 Smith 200 mU/ Ref 1 U Cal int

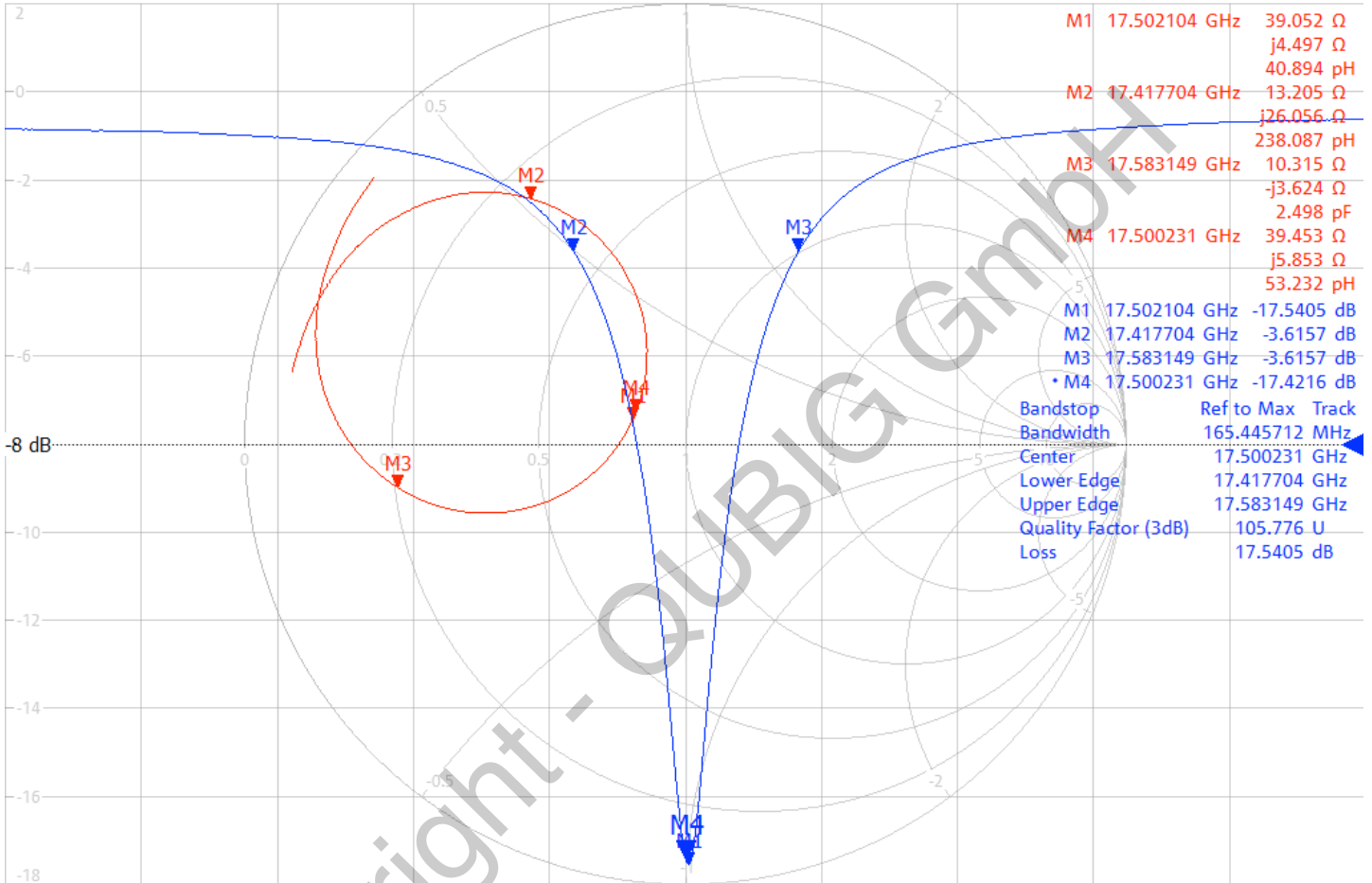

Ch1 Center 17.500104 GHz Pwr 3 dBm Bw 10 kHz Span 1 GHz

Frequency tuning performance @ T=21.0°C

MAX resonance frequency	$f_{0,max}$	17.59	MHz
MIN resonance frequency	$f_{0,min}$	17.44	MHz
number of turns	N_{max}	4	
tuning range		150	MHz
temperature dependence	df_0/dT	-5.2	MHz/°C

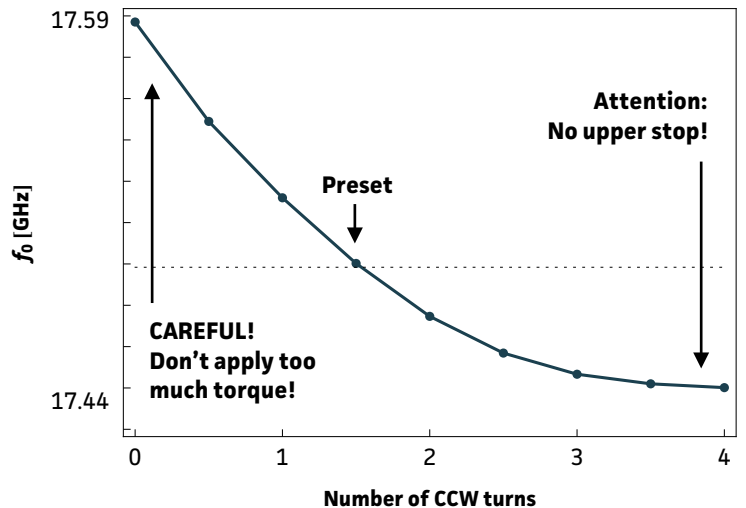

- only use supplied tuning tool
- actuate tuner carefully / do not apply too much torque especially around $f_{0,max}$
- there might be no hard upper or lower stops (!)

Package drawing

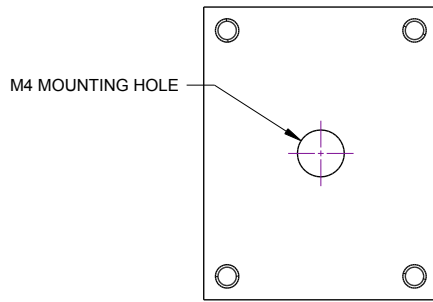

No user serviceable parts inside. None of the screws must be loosened at any time! EOM may get damaged otherwise.

Please handle device carefully. Avoid shock. Don't drop.

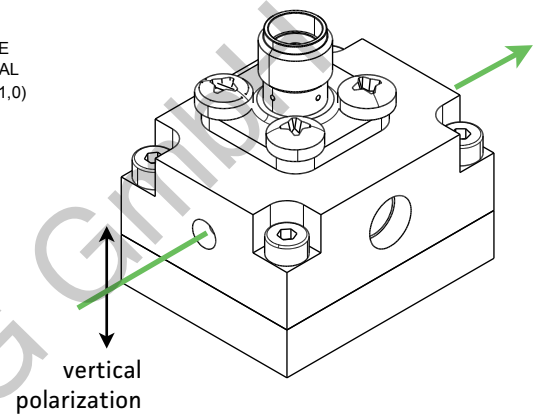
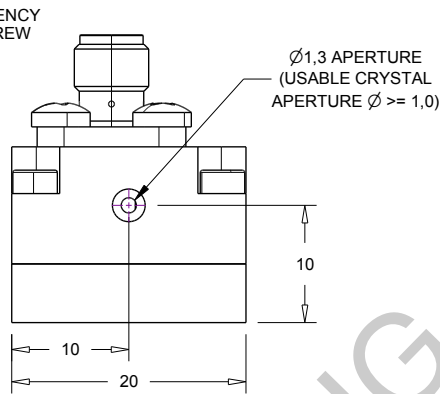
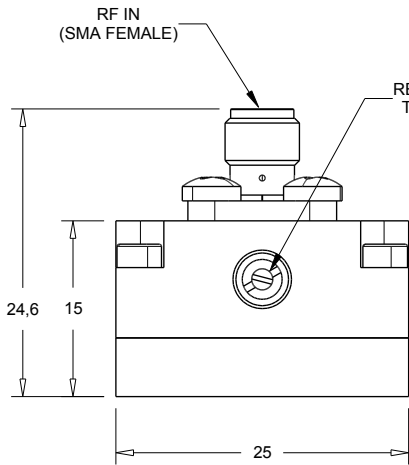

PM-C.37E7..b

All dimensions in mm.

Copy right - QUBIG GmbH

Tested by:

Tel: +49 89 2302 9101
Fax: +49 89 2302 9102
eMail: mail@qubig.com
web: www.qubig.com

Qubig GmbH
Balanstr. 57
81451 Munich
Germany